

SPACIA FIRST | WOOD, STONE & ABSTRACT





ABSTRACT - Linen Weave SF3A3800



ABSTRACT - Bronze SF3A4805

ABSTRACT - Steel SF3A2804



STONE - Dry Stone Loam SF3S4434



STONE - Dry Stone Cinder SF3S4433



STONE - Desert Sandstone SF3S4607

STONE - Dry Stone Alba SF3S4401



WOOD - Warm Maple SF3W2502



WOOD - Honey Oak SF3W2504









WOOD - Dry Cedar SF3W2535

WOOD - White Oak SF3W2548

## PERFORMANCE AND FEATURES







	<p>AVAILABLE SIZES</p>	<p>12" x 12" (305 x 305 mm), 12" x 24" (305 x 610 mm), 18" x 18" (457 x 457 mm), 6" x 36" (152 x 915 mm), 7.25" x 48" (185 x 1220 mm) All with squared edges. Sizes are style dependent.</p>
	<p>LIGHT COMMERCIAL WARRANTY</p>	<p>This product is backed by our Limited 10 year Light Commercial Warranty.</p>

## SUSTAINABILITY

	<p>ENERGY LEADERSHIP</p>	<p>With one of the largest solar arrays in the flooring industry (3.3 acres in Salem NJ) and ambitious goals to improve energy efficiency by 25% over ten years, we have an ongoing partnership with the Department of Energy to lead manufacturing into smarter energy use, as well as to reduce related carbon emissions.</p>
	<p>WATER REDUCTION</p>	<p>Water is a precious natural resource and a key component in manufacturing. By investing in technology and a continual emphasis on efficiency and lean manufacturing, we have reduced our water use by more than 35% since 2007. We also actively help protect wetlands in the communities where we make flooring.</p>
	<p>SOLAR ARRAY</p>	<p>At 3.3 acres, we have one of the largest solar arrays in the flooring industry generating 1,000,000 kilowatt hours annually.</p>
	<p>US MANUFACTURING</p>	<p>Mannington is a fourth generation, family-owned company deeply committed to U.S. manufacturing. We make flooring in eight communities across the U.S., allowing us to provide the highest levels of service and quality in the industry, while supporting local economies and crafting quality, American-made products.</p>
	<p>ISO 14001</p>	<p>ISO 14001 is a global environmental standard that provides a system for continual improvement in environmental performance.</p>
	<p>3RD PARTY CERTIFICATIONS</p>	<p>Certifications help navigate the world of green marketing claims. So we invest in ISO-14001 and environmentally preferable product certifications including NSF/ANSI-140, NSF/ANSI-332, FloorScore, and Green Label Plus. All of our products contribute to multiple LEED and Green Globe credits.</p>



## SUSTAINABILITY



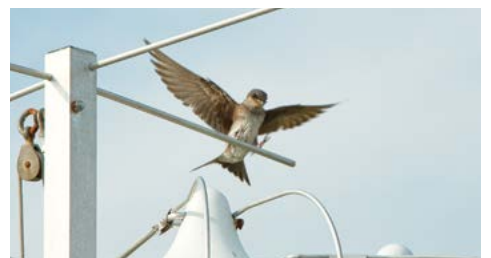









	<p>PURPLE MARTINS</p>	<p>In the mid-1980s, we began attracting migrating birds called Purple Martins to our New Jersey manufacturing campus as a more natural alternative to the use of pesticides. This “Purple Martin Project” has proven to be an incredibly environmentally friendly and cost effective way to control insects. Our employees are engaged in the banding and tracking of the birds.</p>
	<p>HONEYBEES</p>	<p>In 2009, as part of an effort to show how an industrial enterprise can co-exist with the agricultural &amp; farming community and positively contribute to both, Mannington’s New Jersey corporate site began to house honeybees, and now have 5 hives in Salem, NJ and 4 in Eustis, FL. The honey bees are thriving and each year we are able to enjoy and share the honey we produce.</p>
	<p>CE MARK</p>	<p>Certifies that a product has met EU health, safety, and environmental requirements, which ensure consumer safety. Manufacturers in the European Union (EU) and abroad must meet CE marking requirements where applicable in order to market their products in Europe.</p>
	<p>CLIMATE REGISTRY</p>	<p>Mannington is dedicated to reducing our greenhouse gas emissions by 25% over 10 years. Since 2007, a 10% reduction can be attributed to energy efficiencies, process efficiencies, and use of renewable energy. Additional information can be found on <a href="http://theclimateregistry.org">theclimateregistry.org</a>.</p>
	<p>LOOP®</p>	<p>We have a responsible end-of-life plan for the products we manufacture. Through our LOOP® reclamation, we take back post-consumer carpet and closed-loop recycle it back into carpet. We also have closed-loop recycling processes in place for our VCT and LVT products and produce the only carpet-to-hard surface flooring – resilient sheet with 35% recycled content.</p>
	<p>RECYCLED CONTENT</p>	<p>We actively seek out waste streams that clog America’s landfills, looking for innovative ways to use them in new products. On average, 15 tons per month of drywall, the construction industry’s largest waste stream, finds new life in our VCT products. We also reclaim post-consumer carpet and tile from other flooring companies, as well as tires, telephone books, automotive glass, and other waste streams that contribute to landfills, incorporating them into carpet and hard surface flooring.</p>
	<p>ENVIRONMENTAL PRODUCT DECLARATION</p>	<p>EPDs communicate the comprehensive life cycle assessment of a product’s environmental impact and facilitate transparency. Our EPDs conform to international standards and are 3rd party verified by SSC and NSF International.</p>



**SPACIA FIRST | WOOD, STONE & ABSTRACT PRODUCT AVAILABILITY**

	Product Name	Product Code	Collection	Price Point	Surface Finish	Bevelled Edges	6" x 36" (152 x 915 mm)	7.25" x 48" (185 x 1220 mm)	12" x 12" (305 x 305 mm)	12" x 24" (305 x 610 mm)	12" x 24" (305 x 610 mm) Cross Grain	18" x 18" (457 x 457 mm)
WOOD	White Oak	SF3W2548	Wood	Standard	Tick	•	•					
	Natural Oak	SF3W3021	Wood	Standard	Tick	•	•					
	Warm Maple	SF3W2502	Wood	Standard	Tick	•	•					
	Dry Cedar	SF3W2535	Wood	Standard	Barnwood	•	•					
	Honey Oak	SF3W2504	Wood	Standard	Tick	•	•					
	English Oak	SF3W2498	Wood	Standard	Tick	•	•					
	Deep Cherry	SF3W3020	Wood	Standard	Tick	•	•					
	Rich Walnut	SF3W2494	Wood	Standard	Tick	•	•					
	Tudor Oak	SF3W2495	Wood	Standard	Tick	•	•					
	Bitter Walnut	SF3W2492	Wood	Standard	Tick	•	•					
	Frosted Oak	SF3W5020	Wood	Standard	Barnwood	•		•				
	Smoked Grey Oak	SF3W3023	Wood	Standard	Tick	•	•					
	Shadow Oak	SF3W5022	Wood	Standard	Barnwood	•		•				
Pale Ash	SF3W2518	Wood	Standard	Tick	•	•						
STONE	Sift Stone Canvas	SF3S6133	Stone	Standard	Deep Ceramic	•			•			
	Dry Stone Alba	SF3S4401	Stone	Standard	Deep Ceramic	•			•			
	Ceramic Ecru	SF3S3592	Stone	Standard	Ceramic	•						•
	Desert Sandstone	SF3S4607	Stone	Standard	Ceramic	•					•	
	Dry Stone Loam	SF3S4434	Stone	Standard	Deep Ceramic	•						•
	Dry Stone Cinder	SF3S4433	Stone	Standard	Deep Ceramic	•						•
	Linear Stone Shale	SF3S3606	Stone	Standard	Ceramic	•				•		
ABSTRACT	Linen Weave	SF3A3800	Abstract	Standard	Ceramic	•						•
	Steel	SF3A2804	Abstract	Standard	Ceramic	•				•		
	Bronze	SF3A4805	Abstract	Standard	Ceramic	•				•		

**SPECIFICATIONS | SPACIA FIRST**

	CONSTRUCTION	Luxury Vinyl Tile with squared edges
	AVAILABLE SIZES	12" x 12" (305 x 305 mm), 12" x 24" (305 x 610 mm), 18" x 18" (457 x 457 mm), 6" x 36" (152 x 915 mm), 7.25" x 48" (185 x 1220 mm) Sizes are style dependent.
	OVERALL THICKNESS	0.08" (2.0 mm)
	PIECES PER CARTON	27 pcs - 12" x 12"; 19 pcs - 12" x 24"; 12 pcs - 18" x 18"; 18 pcs - 6" x 36"; 9 pcs - 7.25" x 48"
	COVERAGE PER CARTON	27 sq. ft. of 12" x 12"; 38 sq. ft. of 12" x 24"; 27 sq. ft. of 18" x 18"; 27 sq. ft. of 6" x 36"; 21.75 sq. ft. of 7.25" x 48"
	WEIGHT PER CARTON	18.87 lbs. - 12" x 12"; 28.35 lbs. - 12" x 24"; 20.55 lbs. - 18" x 18"; 19.75 lbs. - 6" x 36"; 15.54 lbs. - 7.25" x 48"
	BOXES PER PALLET	72 ct. of 12" x 12"; 60 ct. of 12" x 24"; 72 ct. of 18" x 18"; 72 ct. of 6" x 36"; 90 ct. of 7.25" x 48"
	3RD PARTY CERTIFICATION	FloorScore, Industry wide 3rd party Type III EPD (Environmental Product Declaration)
	LIGHT COMMERCIAL WARRANTY	This product is backed by our Limited 10 year Light Commercial Warranty.
	LEED	Mannington Commercial products may contribute to multiple LEED credits.
	US MANUFACTURING	Mannington is a fourth generation, family-owned company deeply committed to U.S. manufacturing. We make flooring in eight communities across the U.S., allowing us to provide the highest levels of service and quality in the industry, while supporting local economies and crafting quality, American-made products.
	LOOP®	Mannington's next closed-loop recycling program, we are reclaiming and recycling end-of-life LVT into new LVT. This further extends our ability to keep post-consumer LVT out of landfills and reducing the environmental impact of our products. Contact your local Mannington representative, or call 800.241.2262 ext. 6211.
STATIC LOAD LIMIT		750 PSI
SPECIFICATIONS (ASTM F-1700)		Class 3, Type B
HEAT STABILITY (ASTM F-1514)		Passes
STAIN & CHEMICAL STABILITY (ASTM F-925)		Passes
HUD/ FHA REQUIREMENTS		Exceeds
ADA		Meets or exceeds ADA Requirements
COEFFICIENT OF FRICTION		COF ≥ 0.5 Leather; 0.6 Rubber
FLOORING RADIANT PANEL TEST (ASTM-E-648)		Passes - Class 1
N.B.S. SMOKE CHAMBER TEST (ASTM-E-662)		< 450 (non-flaming mode)
INSTALLATION ADHESIVE		Amtico 373 / Full Spread Porous & Non-Porous Subfloor, Amtico PS - High Moisture Adhesive /Transitional Pressure Sensitive/ Full Spread Porous & Non-Porous Subfloor, Amtico Universal 2-Parts/ Full Spread Non-Porous Subfloor, XpressStep Spray Adhesive / RH 90%, MVER 8, pH 11, XpressStep Premium Spray Adhesive / RH 93%, MVER 10, pH 12. <i>Note: Must use Amtico Universal 2-Parts or XpressStep Adhesive under hospital beds and heavy rolling loads or where high performance is needed.</i>



